

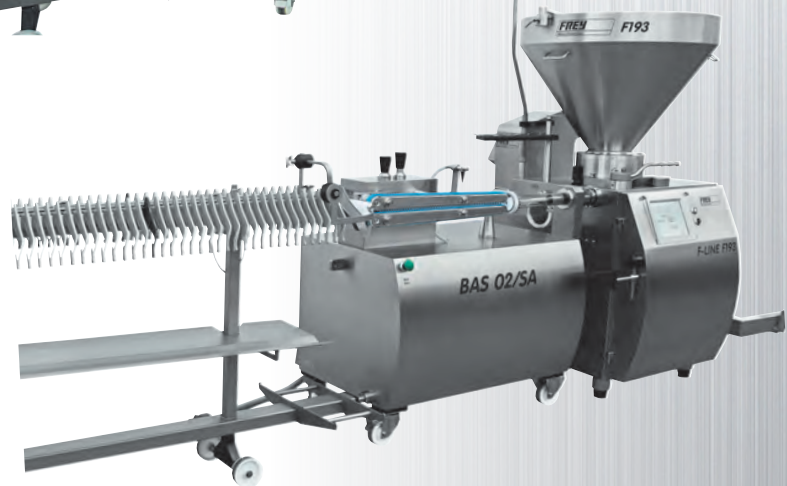

FREY

Maschinenbau



Industrial production of sausages with BAS, KAS & AHL

Belt linking system, chain linking system & hanging line

Using our linking- and hanging lines an even higher production performance can be achieved. The result is a fully automatic operation with only little manpower. The systems can be used for artificial, cellulose, collagen and natural casings. Multiple combination options with our filling machines are possible. The systems can be combined from F-Line F100.



Belt linking system BAS 02/SA

BAS 02/SA

With BAS02/SA in connection with the casing holder device DHGA offers the highest rationalization level due to the fully automatic opening and closing of the complete unit.

The integrated servo linker guarantees the utmost accuracy, working speed and process reliability. Thanks to the straight and short ways of the product even critical products, like raw sausages can be produced fast without any problem.

BAS02/SA can be combined with the grinding systems WK98/WK132. The product quality can considerably be improved.

The BAS-system is mobile and can easily be connected to the filling stuffer with the ball joint connector. This ensures shortest possible set-up times. The machine is completely made of stainless steel and meets the highest hygienic standards.

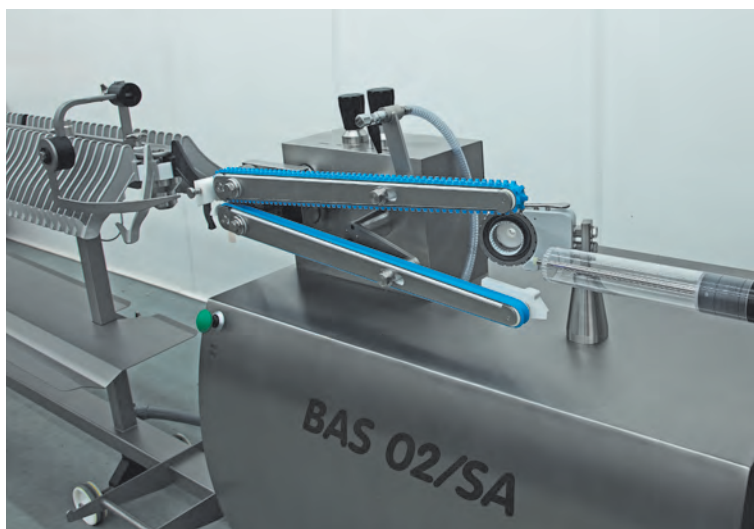
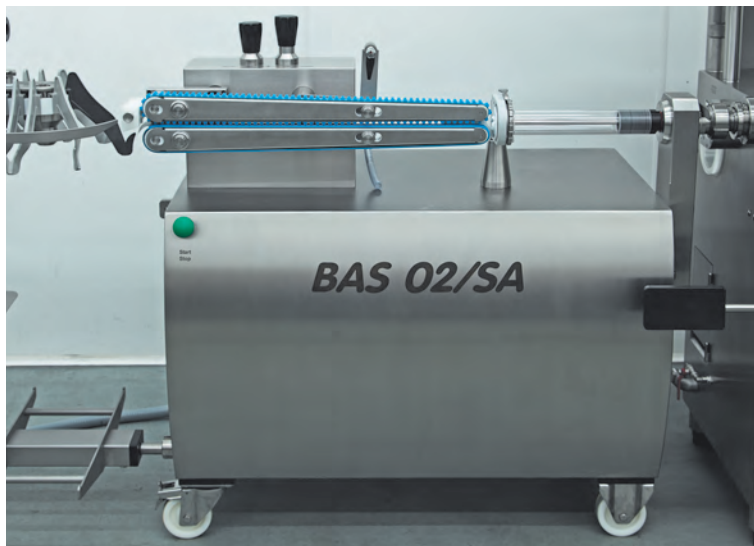

BAS 02/SA

The BAS-system optimizes the production of sausages with an equal length and weight. The BAS-system can be used for artificial, cellulose, collagen and natural casings. With our BAS-system a higher and constant working performance of your filling station can be achieved.

The BAS-system is driven by a servo motor with positioning regulation. This servo motor is synchronized by the FREY CAN BUS system with the stuffer which has been connected in series. Hereby the sausages led through the belt are produced in equal length. Differences in calibers of the casings can be compensated.

BAS 02/SA - Application range

FREY
Maschinenbau

BAS 02/SA (semi automatic)

- Equal in length
- Equal in weight
- Integrated high speed servo linker
- Pneumatically driven DHGA

BAS 02/SA in connection with AHL 02

- Additional hanging function
- On special request a higher hook position 120 mm is possible

BAS02/SA can be used for natural, collagen and artificial casings. BAS 02/SA can be combined with our grinding systems WK98 / WK 132 or with our casing spooler DA2012 / DA2013.

Operation

The operation is centrally controlled via the filler control TC733. All necessary parameters can be set and saved in the filler program. A flexible change of sorts is possible.

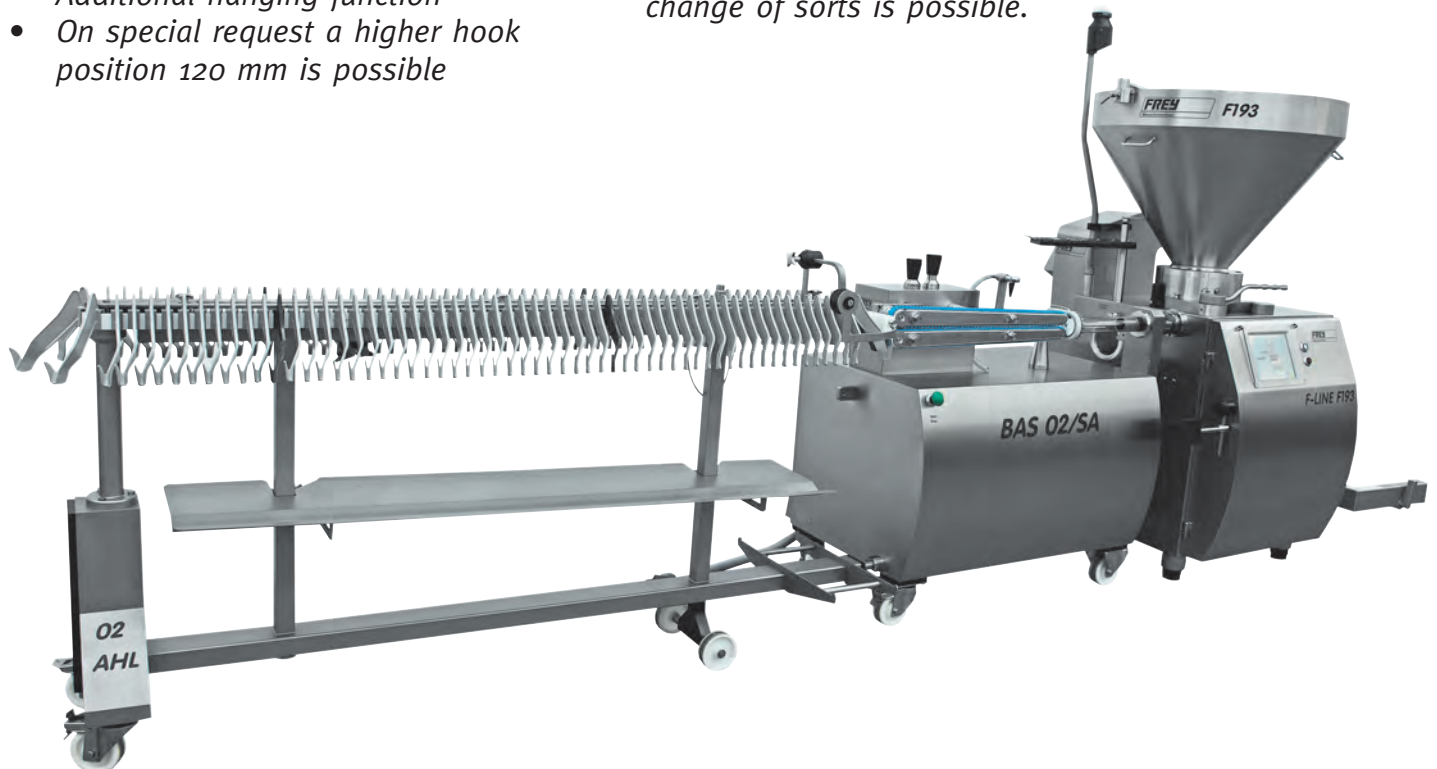

Advantages:

- Highest linking performance
- Shortest preparation time for casings
- Flexible and simple use
- With integrated water injection

BAS 02/SA can also be used with our filling stuffers of the P-Line. For our grinding + systems WK98/ WK132 an additional servo drive in the filling stuffer is necessary.

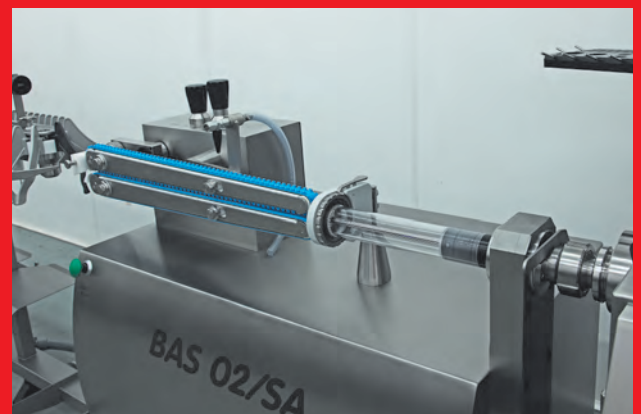

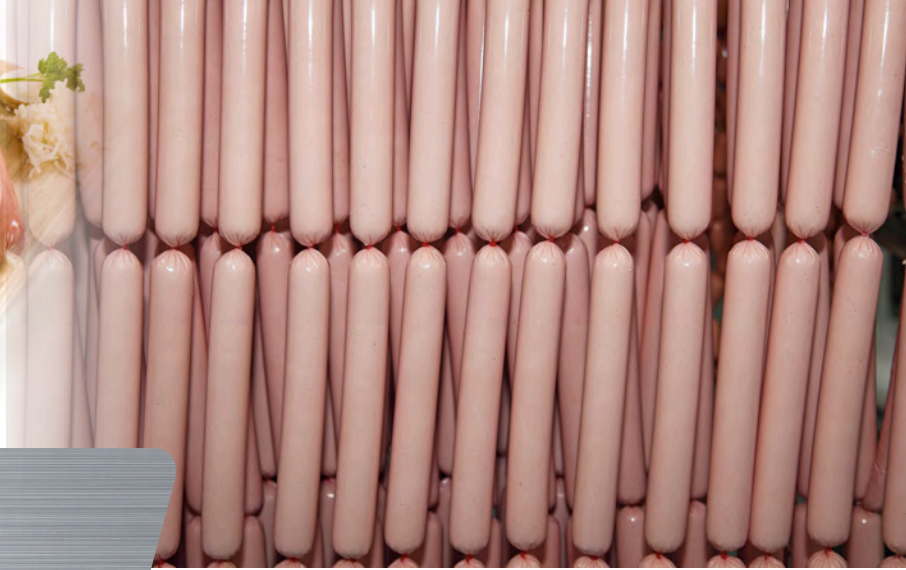

KAS 01 - Chain linking systems

Application range

The chain linking system, short KAS, has been designed for a high linking performance with only little manpower. The main focus of the development was the implementation of an EASY operation, EASY cleaning and EASY disassembly. The attachment is mobile and due to the advanced portioning belts, a linking performance of max. 2000 sausages per minute can be achieved. The sausage lengths and calibers are individually adapted to the customer's demand. Here the customer has the choice of a sausage length from 30 mm to 330 mm and a caliber from 13 mm up to a diameter of 38 mm. The KAS can be combined with WK98/WK132 as well as WS420 or AHL02.



Advantages

The attachment system KAS - a half automatic chain linking system - allows an even faster change of casings thanks to the rotating twin head. KAS can be used for natural, collagen and artificial casings. By using our KAS-system you can achieve an even higher and constant work performance of your filling station. Adapted to synchronisation of the FREY CAN BUS system with the preceding filling stuffer.



Composition of KASo1

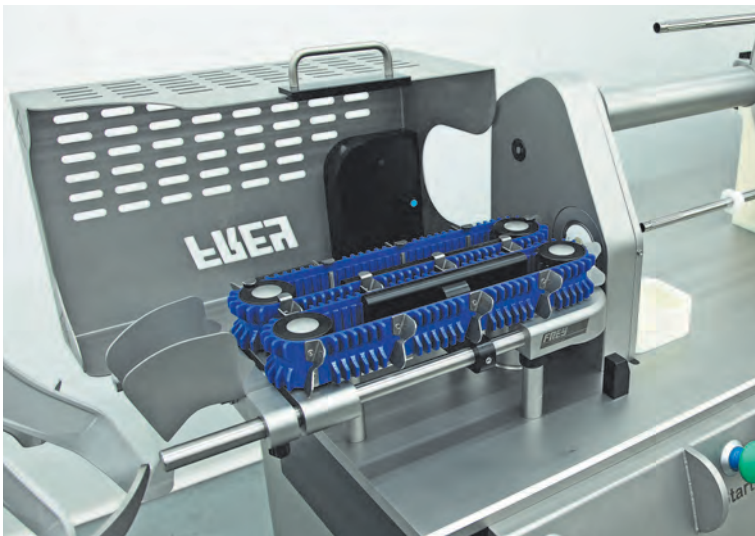

Portioning unit

Simple and uncomplicated change of products due to a toolfree plug system. The product can be prepared on different portioning heads before starting the production so that there is no loss of time during the filling process. Firmly fixed pinches ensure always an exact sausage length, irregularations in caliber of the casings thereby can be compensated. The whole portioning unit is protected by a robust safety-cover with integrated visual slots, sensors, a wetting system and a rinsing nozzle.

Twin head

The heart of our KAS system is the twin head where two of our proved linking systems have been installed. The filling tube diameters range from 9 mm to 24 mm. Only with one single operation it can toolfree be dismantled for the cleaning process.

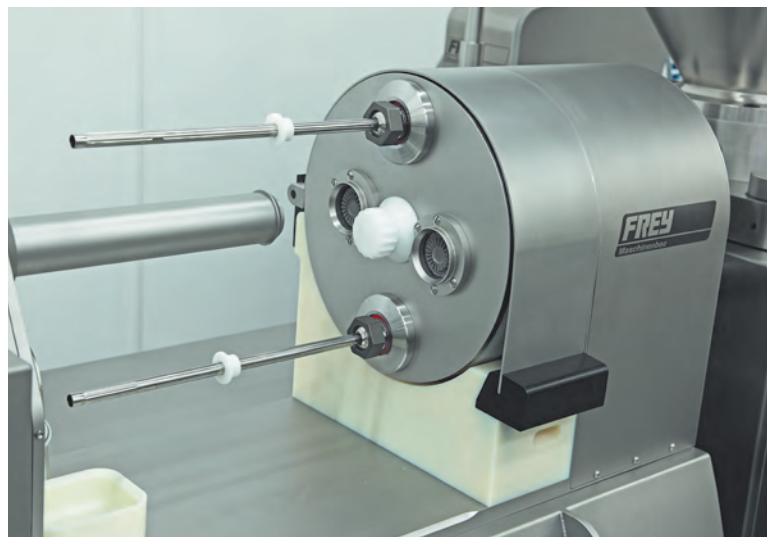

For an exact positioning of the portioning belts as well as for linking each one precise and dynamic servo motor is being inserted. The heart of our KAS system is the twin head where two of our proved linking systems have been installed.

After changing the filling tube a stepper motor ensures the exact positioning of the rotary motor. Two of our proved linking gears have been installed in the twin head.

The operation is centrally controlled via the filler control TC733. All necessary parameters can be set and saved with the filler program. A flexible change of sorts is possible. Furthermore an identification of casings for a fully automatic stop by means of a Smart laser identification sensor is integrated in the KAS.



AHL 02 - hanging line

AHL 02

The hanging line system AHL can be connected with the BAS 02/SA & KAS 01. At the taking-over point the sausages are taken over by the hanging line and transported onto flexible hooks. The distance between the hooks can be modified by using the plug-in system.



The following functions of the AHL are available:

- Group Mode
- Continuous Mode (endless)

The hook-distances are selectable:

- Pieces on the first hook
- Pieces on all hooks
- Hook groups
- Empty hooks
- Empty portions
- Approach and take-over ways
- Approach and take-over speed
- Automatic piece calculation

By using acceleration ramps the servo drive of the hanging line allows to adjust the driving speed also to sensible products.

AHL 02 systems are movable and can flexibly be used.

The electronic control elements are integrated in the BAS 02/SA & KAS 01 system and are well-protected. The machine is connected via a waterproof plug.

TC733 - is controlling the sausage production

All parameters can be set via the filler control TC733. The control supports the input of the parameters with different calculation programs, for the determination of the sausage length and filling speed. Three different working modes are possible.

Calibers of 13 - 38 mm and sausage lengths of minimum 30 mm can be produced.





WS420 - sausage cutter



Advantage

- Needs few space due to the compact overall size
- Continuous cutting performance
- Accurate cutting due to an easy alignment of the cutting point
- Simple product feeding with automatic alignment.
- Easy cleaning
- Suitable for the use with automatic filling and packing lines

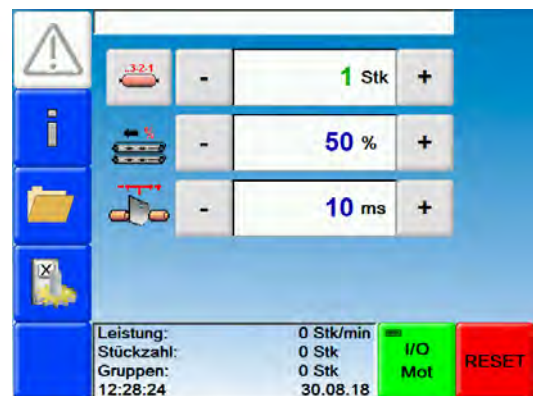

Survey of functions:

- Belt speed infinitely adjustable
- Cut rate infinitely selectable from 0 - 99
- Memory for 99 cutting programs
- Counter of pieces
- Status display
- Diagnosis programme
- CAN Bus, Ethernet- and USB interface
- WS Food interface



Professional application thanks to an innovative vacuum technology

The sausage cutter WS420 can be used for the production of fresh, cooked, smoked and raw products in natural, collagen and cellulose casings. WS420 marks out by a high working performance and an exact cut. The mechanical scissors work alternately. Per stroke one cut. The feeding is performed via a big hopper aligning automatically the product.

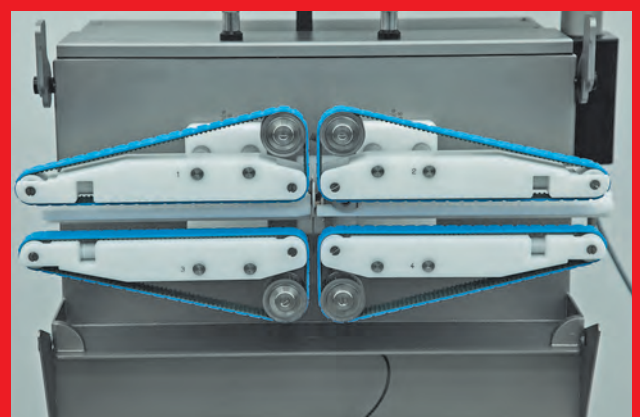

Technical data

BAS 02/SA with integrated half-automatic DHGA:

Caliber	13 - 38 mm
Portion length	30 - 500 mm
Max. portion speed	800 port/min.
Drive mode	FREY Top Line
Connected load	6,9 kW
Voltage/Tension	3Ph./PE, 400V, 50/60Hz
Compressed air	6 bar / 7 L/min.
Weight	370 kg
Accessories	set of belts, 1 slide 2 linking tubes 380 1 DHGA integrated

KAS 01:

Caliber	13 - 38 mm
Portioning length	30 - 330 mm
Modular length	in 10 mm steps
Max. portioning speed	2.000 port/min.
Length of filling tube	380 mm
Drive mode	FREY Top Line
Connected load	7,0 kW
Voltage/tension	3Ph./PE 400V, 50/60Hz
Compressed air	6 bar / 10 L/min.
Water connection	required
Weight	600 kg
Accessories:	net and connecting cable for FREY-stuffers, 2 sets of portioning heads on customer's choice, Accessories holder

AHL 02:

Connection	to BAS02/SA & KAS 01
Drive mode	FREY Top Line
Connected load	0,56 kW
Voltage/Tension	3Ph./PE, 400V, 50/60Hz
Finish:	stainless steel, mobile
Weight	140 kg
Adjustable in height	950 mm - 1150 mm
Accessories:	120 hooks, base sheet, deflector

WS420:

Industrial PC control, 5,7" TFT colour display (800x600)	
max. cutting performance	420 pieces / min.
Diameter of the sausages	13 - 36 mm
Sausage length	> 30 mm (depending on the casing)
Max. belt speed	48 m / min.
Connected load	1,0 kW
Voltage/tension	230 Volt, 50/60 Hz
Compressed air	
with max. cutting performance	6 bar /6 L/min.
Weight including chassis:	abt. 130 kg
Adjustable in height	1050 mm - 1100 mm

Special accessories:

In order to meet your product diversity you can receive special filling tubes or other additional equipment from us on demand, individually made for you. On the Frey accessories trolley all accessories find their place.





Drawings of BAS 02/SA

BAS 02/SA & AHL 02:

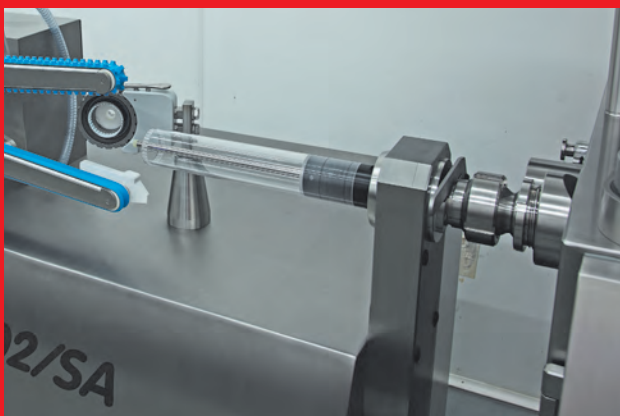
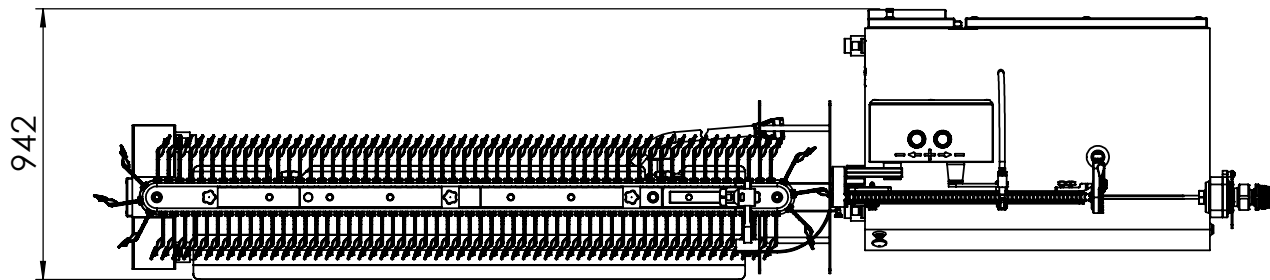
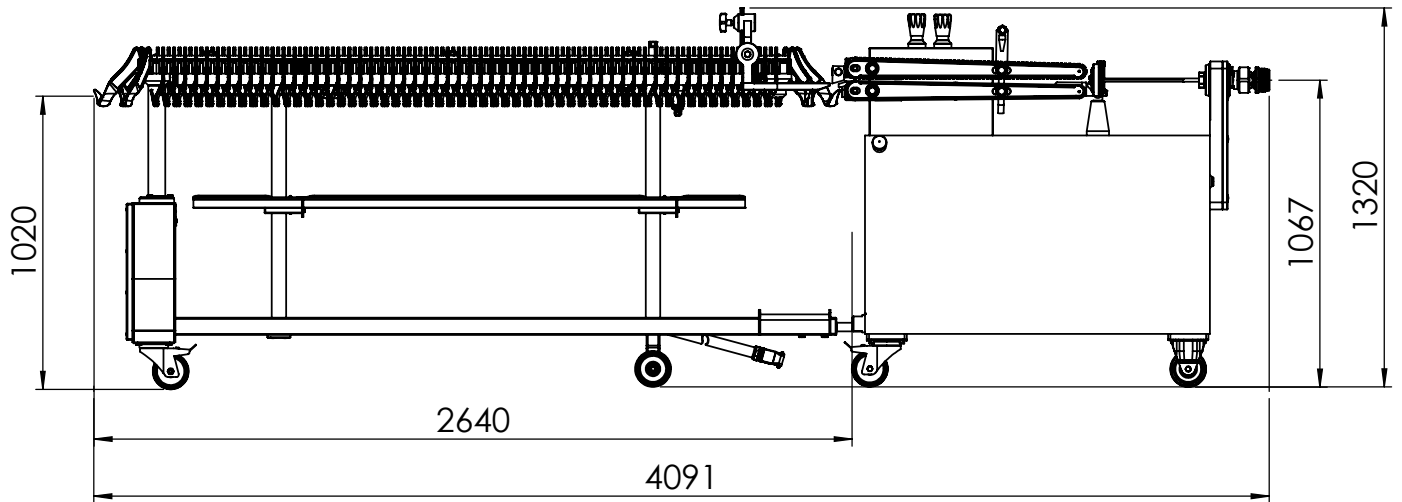



Drawings of BAS 02/SA

BAS 02/SA:

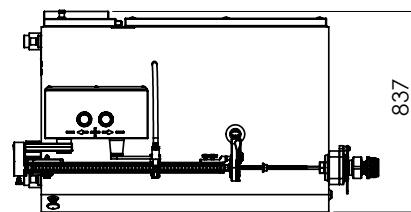
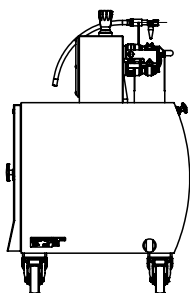
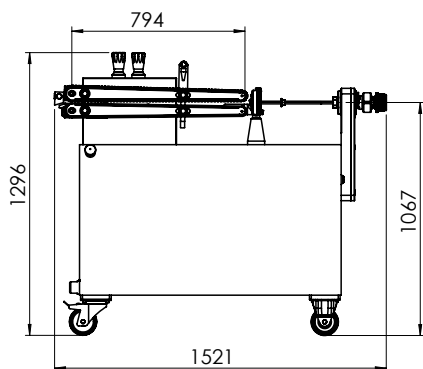

BAS 02/SA & WS420:

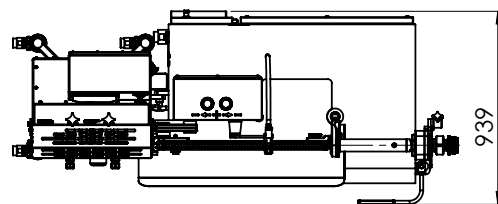
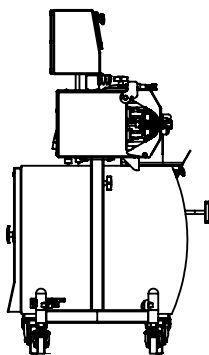
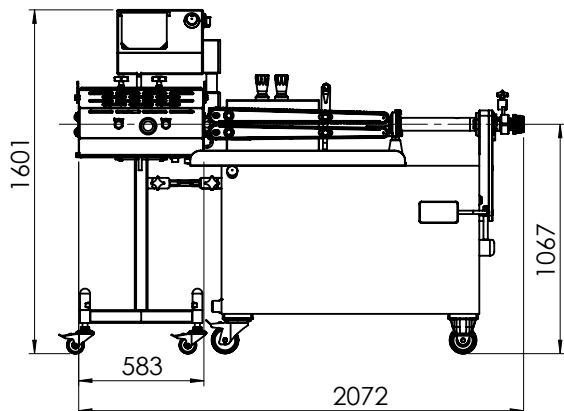



Drawings of KAS 01

KAS 01 & AHL 02:

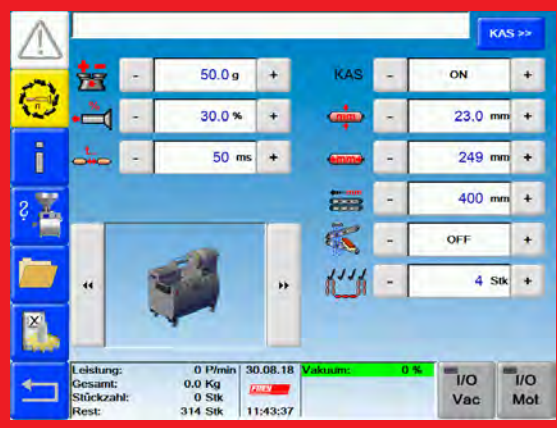
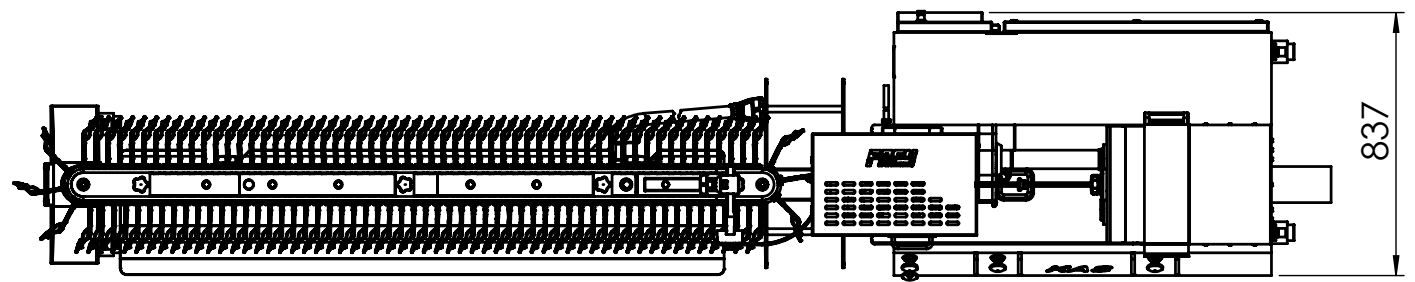
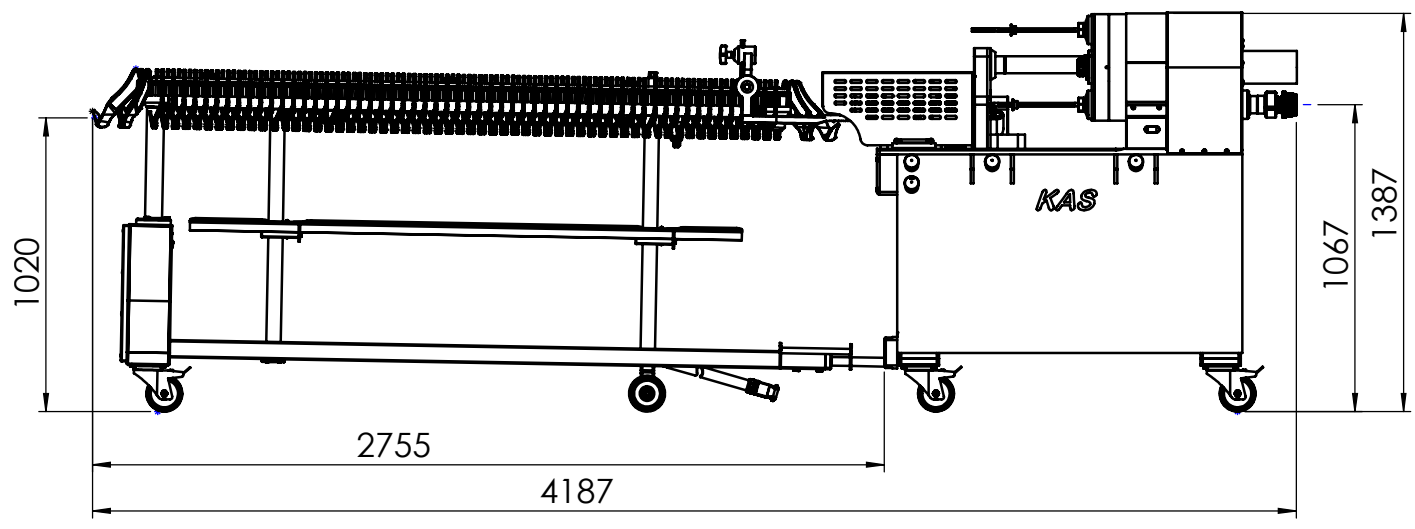

Drawings of KAS 01

KAS 01:

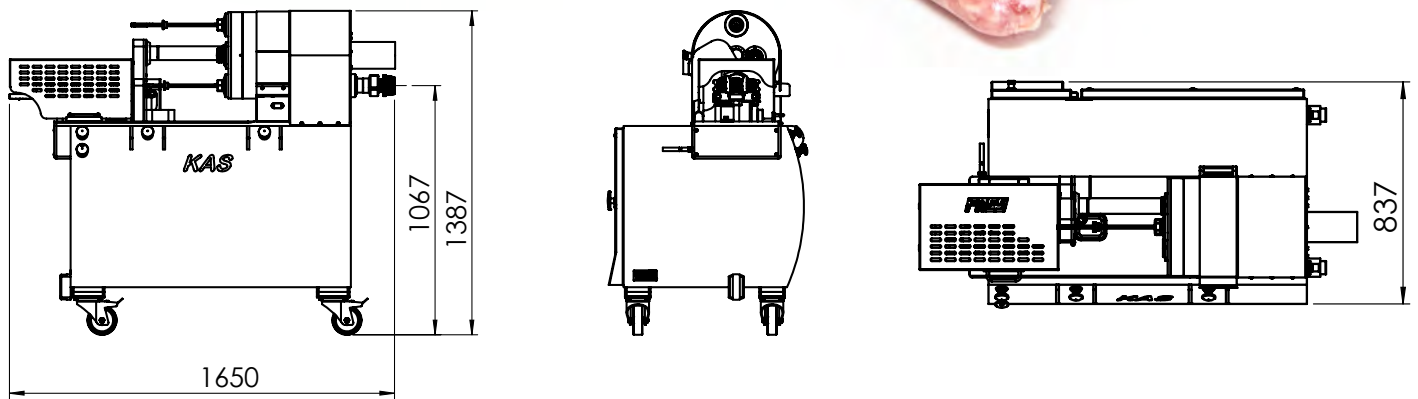

KAS 01 & WS420:

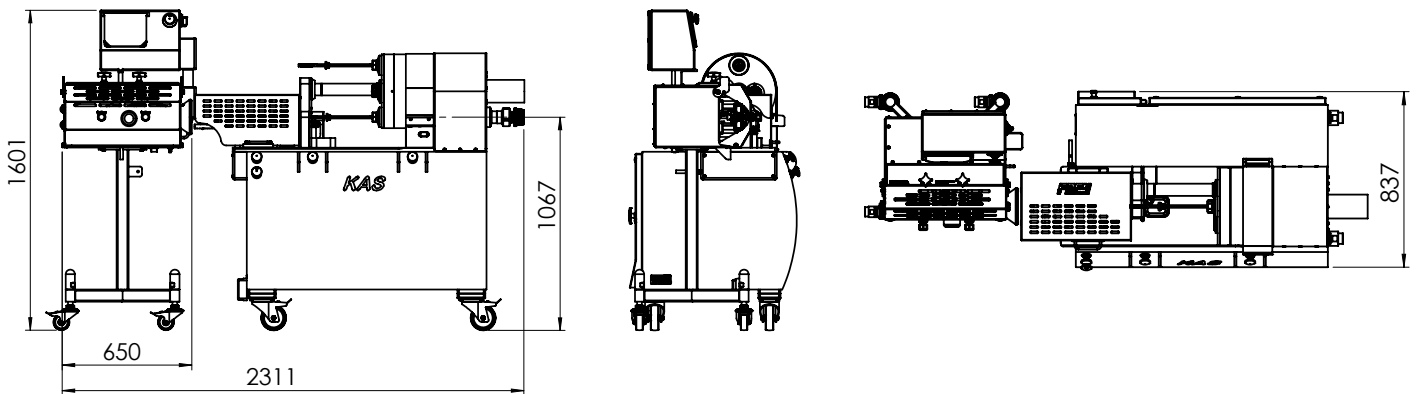

Heinrich Frey Maschinenbau GmbH

Fischerstr. 20

89542 Herbrechtingen

Deutschland / Germany

Phone: +49 7324 172 0

Fax: +49 7324 172 44

www.frey-online.com

info@frey-online.com

Technical modifications are subject to change